

Clarke®

PUMP



ENGINE DRIVEN SEMI TRASH 2" PUMP

MODEL NO: PS50

PART NO: 7230167

OPERATION & MAINTENANCE INSTRUCTIONS

UK
CA | CE

ORIGINAL INSTRUCTIONS

GC1124

INTRODUCTION

Thank you for choosing this CLARKE Pump. Before attempting to use this product, please read this manual thoroughly and follow the instructions carefully. In doing so you will ensure the safety of yourself and that of others around you, and you can look forward to your purchase giving you long and satisfactory service.

The function of this pump is to move clean /dirty water (with solids in suspension up to 15 mm in diameter).

DO NOT use it to pump:

- Sewage
- Dangerous liquids - (Flammable or corrosive)
- Salt water

Before you use this pump read the manual fully.

GUARANTEE

This pump is guaranteed against faulty manufacture for a period of 12 months from the date of purchase.

Please keep your receipt which will be required as proof of purchase.

This guarantee is invalid if the pump has been abused, tampered with, or not used for its primary function.

Faulty goods must be returned to their place of purchase, no pump can be returned to us without prior permission.

This guarantee does not effect your statutory rights.

INVENTORY

You should find the items in the list below in the carton.

1 x Petrol Powered 2" Water Pump	2 x Rubber Sealing Rings
2 x 2" BSP Inlet/outlet fittings	1 x Spark Plug Box Wrench
1 x Plastic x Inlet Strainer (in two pieces)	6 x Hose Clips

Speak to your CLARKE dealer If items are missing or damaged.

GENERAL SAFETY RULES



WARNING: WHEN USING PUMPS, ALWAYS FOLLOW BASIC SAFETY PRECAUTIONS TO REDUCE THE RISK OF FIRE, ELECTRIC SHOCK AND PERSONAL INJURY. READ ALL INSTRUCTIONS BEFORE YOU OPERATE THIS PUMP AND SAVE THEM FOR FUTURE REFERENCE.

1. **ALWAYS** obey all safety precautions for the handling of fuel.
2. **ALWAYS** make sure that you are familiar with this pump, and follow all instructions in this manual.
3. **ALWAYS** make sure that the pump is positioned correctly to prevent it from moving during operation.
4. Keep the area adjacent to the pump clear.
5. **ALWAYS** connect the strainer to the suction hose to stop stones and other solids from being pulled into the pump. These can cause damage to the pump.
6. **ALWAYS** keep the pump dry and clear of discharge hose.
7. Only use parts supplied by the manufacturer. Using non-standard parts can be dangerous.
8. **ALWAYS** use at least 300mm of flexible hose to make plumbing connections to the pump. Rigid piping can put stress on the pump, causing damage. If you use rigid piping, it must be supported to eliminate stress on the connections.
9. **DO NOT** refuel the engine while it is operating and let the engine cool sufficiently before refuelling.
10. **DO NOT** use to pump petrol (or other flammable liquids), or corrosive chemicals. The function of this pump is to pump **WATER ONLY**.
11. **DO NOT** operate this pump in an explosive atmosphere, near combustible materials, or where there is insufficient ventilation.
12. **DO NOT** let children use this pump.
13. **DO NOT** run the pump dry. **ALWAYS** fill the pump with water before starting.
14. **DO NOT** direct the discharge flow towards another person.
15. **DO NOT** over-tighten drain or filler plugs. Excessive force can damage the threads or the pump body.
16. **DO NOT** direct the water discharge towards electrical wiring or equipment.

GENERAL SAFETY IN THE WORKPLACE

1. **ALWAYS** keep work area clean & tidy. Cluttered work areas invite accidents.
2. **NEVER** over-reach. Keep proper footing and balance at all times.
3. **ALWAYS** make sure that the workplace is well lit. Make sure that that lighting is placed so that you will not be working in your own shadow.
4. Dress correctly. Loose clothing or jewellery can get caught in moving parts. Non-slip footwear is recommended. Wear protective hair covering to contain long hair.
5. **ALWAYS** wear safety glasses. (Everyday glasses are not safety glasses).







CARE OF PUMPS

1. The CLARKE service department can replace damaged components.
2. **ALWAYS** examine the pump for damage that can effect the operation of the pump. Repair any damaged parts.
3. Have your pump repaired by a qualified person. Repairs must only be carried out by qualified persons using original spare parts.

Keep the instructions for future reference.

SAFETY SYMBOLS

The meanings of the markings and symbols on the pump are shown below

	Read this manual before use and keep it for future reference		WARNING: Hot surfaces
	Wear ear protection when in operation		WARNING: Adhere to safety information on label
	WARNING: Loud noise when in operation		WARNING: Flammable substances

ASSEMBLY

INSTALL THE SUCTION HOSE

1. Fit the rubber washer into the adaptor making sure that it is seated correctly.
2. Screw the adaptor onto the pump securely.
3. Slide the hose on to the adaptor and lock in position with the jubilee clip supplied.
4. Install the strainer on to the other end of the hose using the other clip supplied.

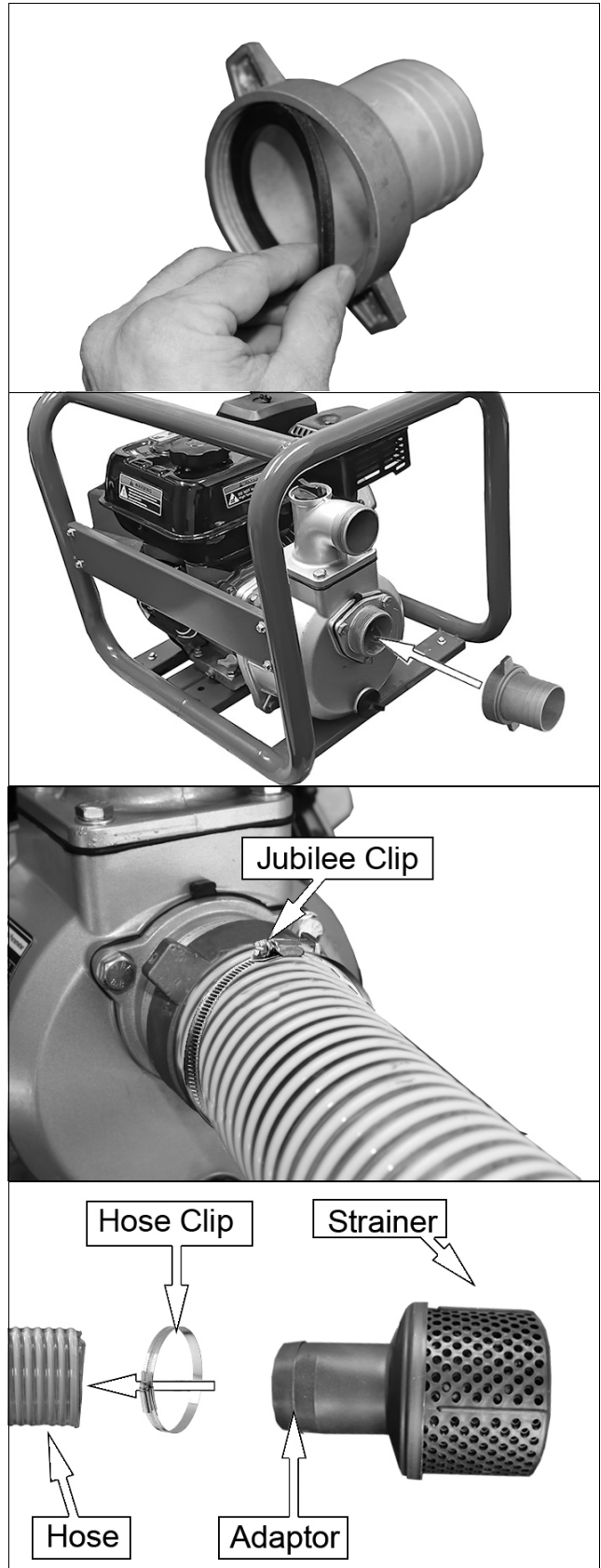

INSTALL THE DISCHARGE HOSE

1. Fit the rubber washer into the other adaptor making sure it is seated correctly.

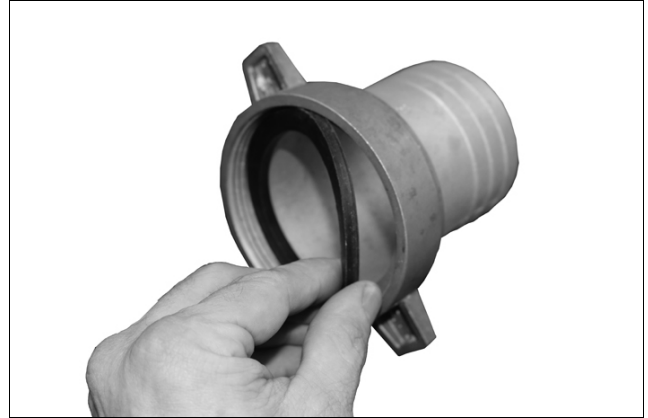

2. Screw the adaptor onto the pump securely.



3. Slide the hose on to the adaptor and lock in position with the jubilee clip supplied.

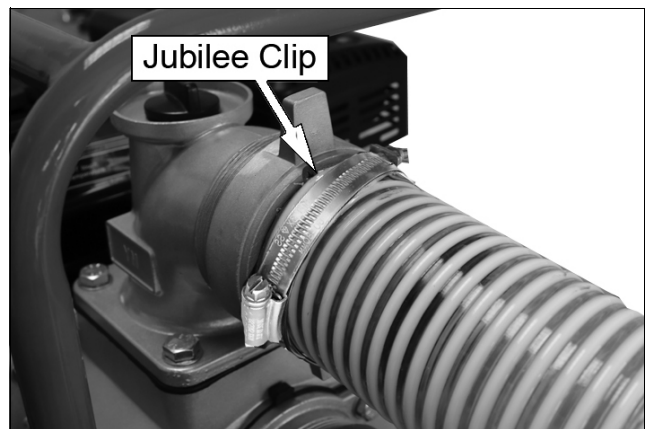

BEFORE USE

PUMP PLACEMENT

For best pump performance, place the pump near the water level, and use hoses that are no longer than necessary. That will enable the pump to produce the greatest output with the least self-priming time.

As head (pumping height) increases, pump output decreases. The length, type, and size of the suction and discharge hoses can also significantly affect pump output.

Discharge head capability is always greater than suction head capability, so it is important for suction head to be the shorter part of total head

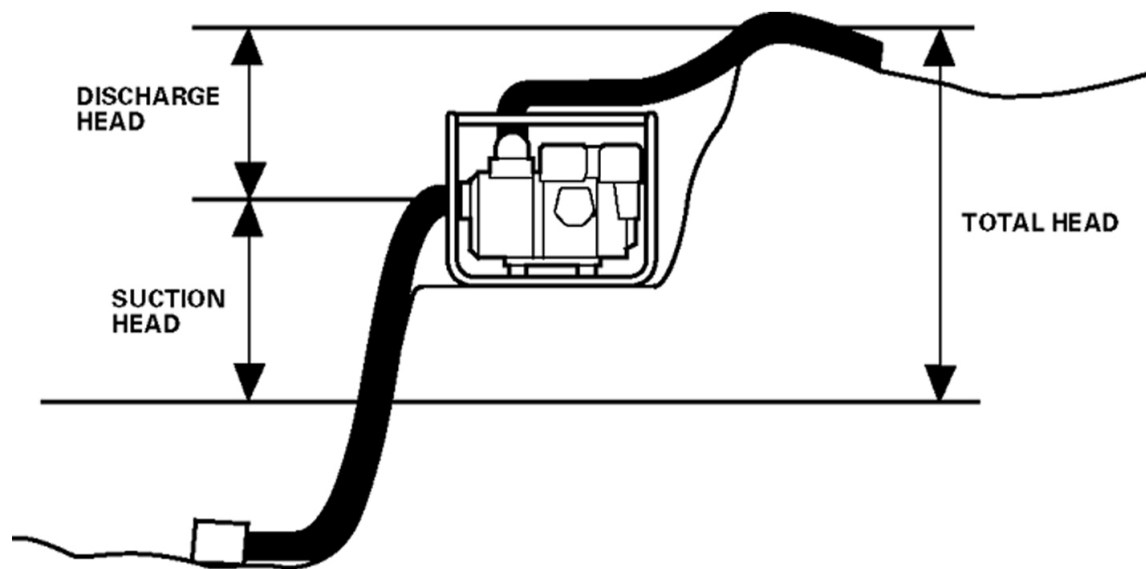

CHECKING/FILLING THE ENGINE OIL BEFORE USE



WARNING: TO DO THIS CHECK, PUT THE PUMP ON LEVEL GROUND WITH THE ENGINE SWITCHED OFF.

WARNING: TAKE CARE NOT TO TOUCH ANY HOT PARTS OF THE PUMP WHEN CHECKING THE OIL LEVEL.

NOTE: The pump will normally be shipped without oil in the engine and will require filling before use.

1. Turn the oil filler cap anti-clockwise and remove from the oil fill tube.
2. Clean the dipstick with a clean cloth.
3. Put the dipstick into the oil fill tube and then remove it again. **DO NOT** screw in the oil filler cap/dipstick when doing this.

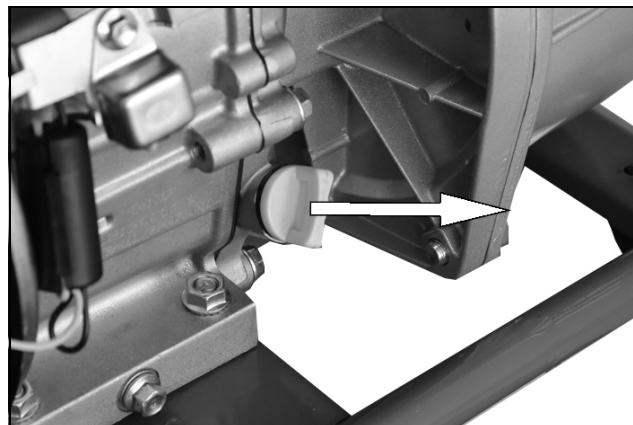

4. If the oil level is at or below the 'L' mark on the dipstick, add oil to the crankcase.
 - Fill until the oil touches the threads in the oil fill tube.
 - Oil capacity (See page 20).
 - We recommend that you use CLARKE SAE10W30 oil (Part No: 3050845) in this pump available from your CLARKE dealer.



5. Replace the oil filler cap.

ADD FUEL



WARNING: REFUEL IN A VENTILATED AREA, AWAY FROM SOURCES OF IGNITION.

WARNING: IF THE ENGINE IS HOT, LET IT COOL BEFORE REFUELING.

WARNING: KEEP FUEL OUT OF THE REACH OF CHILDREN.

RECOMMENDED FUEL

Only use unleaded petrol.

1. Remove the fuel tank cap.
 - In the fuel tank is a fuel filter which collects contaminants as you refuel.
2. Carefully add fuel to the fuel tank.
 - Make sure that the fuel filter is free of contamination.
 - The max capacity of fuel is 3.6L.
3. Replace the fuel tank cap.



OPERATION



WARNING: WHEN YOU OPERATE THE PUMP, THE EXHAUST MUFFLER WILL BE VERY HOT.

WARNING: DO NOT OPERATE THE ENGINE IN A CLOSED SPACE, MAKE SURE THAT THERE IS SUFFICIENT AIRFLOW AROUND THE PUMP DUE TO HARMFUL EMISSIONS/ FUMES FROM THE ENGINE.

PRIME THE PUMP

The pump must be primed before use.

1. Before starting the engine, remove the filler cap from the pump chamber.

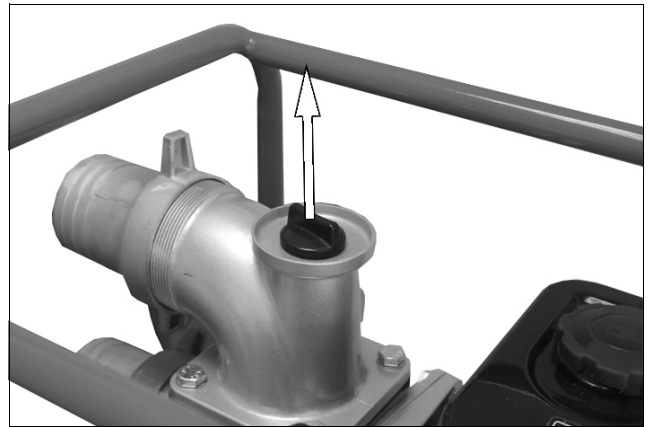

2. Fill the pump chamber and inlet hose with water.

NOTE: A foot valve (not supplied) connected to the lower end of the inlet hose between the hose and the strainer will help to maintain priming,

3. Replace the filler cap and tighten it securely.

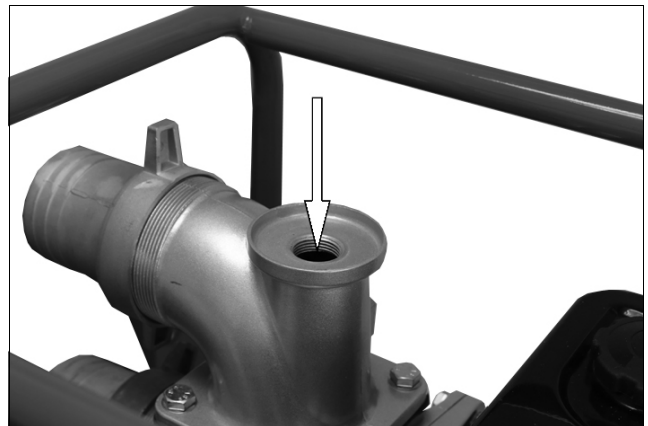

WARNING: OPERATING THE PUMP DRY WILL DESTROY THE PUMP SEAL. IF THE PUMP IS OPERATED DRY, STOP THE ENGINE IMMEDIATELY AND LET THE PUMP COOL BEFORE PRIMING

STARTING THE ENGINE

1. Set the fuel valve to the ON position.



2. To start a cold engine, move the choke lever to the 'ON' position.
 - To restart a warm engine, move the choke lever to the 'OFF' position.



3. Move the throttle lever away from Slow about 1/3 of the way.

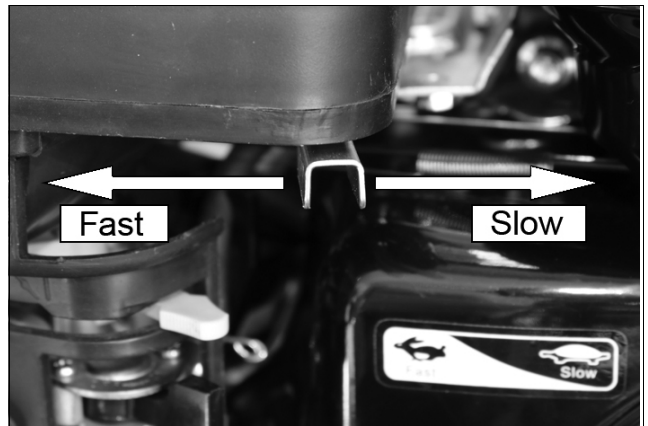

4. Set the engine switch to 'ON'.

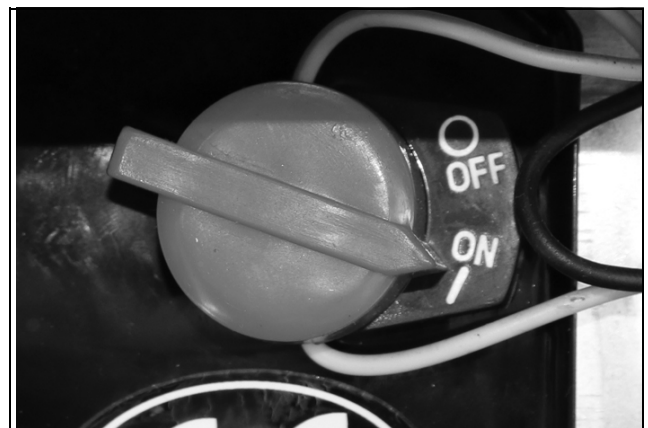

5. Pull the starting handle lightly until you start to feel resistance. Then pull up and away suddenly to start the engine.

NOTE: You might need to do this more than once.

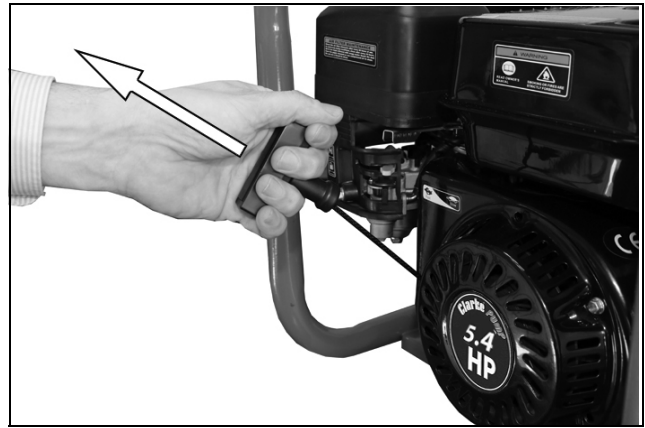

WARNING: WHEN THE PUMP HAS STARTED, RELEASE THE STARTING HANDLE SLOWLY TO PREVENT INJURY/DAMAGE AS IT RETURNS.

6. Once the engine has warmed up from a cold start, move the choke lever to the 'OFF' position.

SETTING THE ENGINE SPEED

After starting the engine, move the throttle lever to the FAST position for self-priming and check pump output.

Pump output is controlled by adjusting engine speed.

- Moving the throttle lever in the FAST direction will increase pump output.
- Moving the throttle lever in the SLOW direction will decrease pump output.

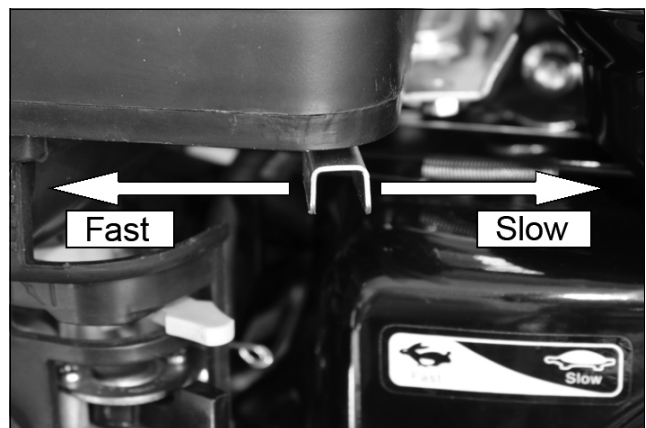

SHUTTING DOWN THE PUMP

To stop the pump in an emergency, set the engine switch to 'OFF'.

1. Use the throttle lever to decrease engine speed to minimum.

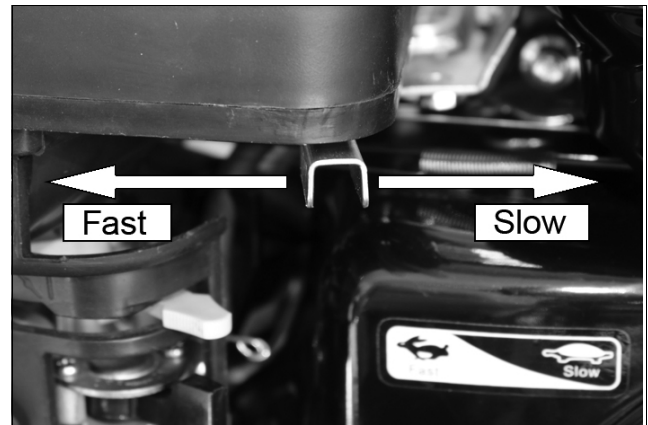

2. Set the engine switch to "OFF".



3. Turn the fuel valve to "OFF".

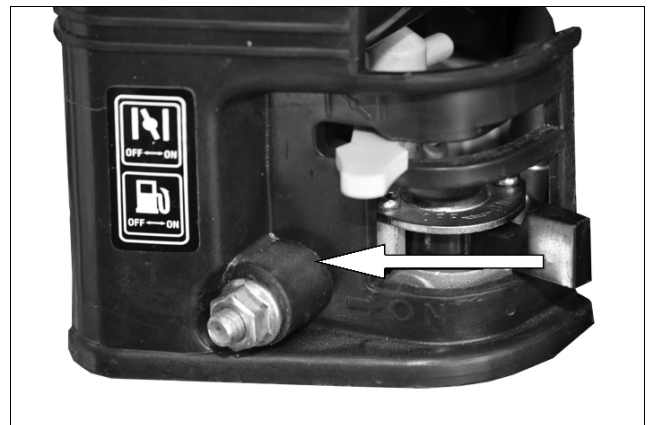

AFTER USE

1. Remove the pump drain plug and drain the pump chamber.
2. Remove the filler cap and flush the pump chamber with clean, fresh water.
 - Allow the water to drain from the pump chamber.
3. Reinstall the filler cap and drain plug.

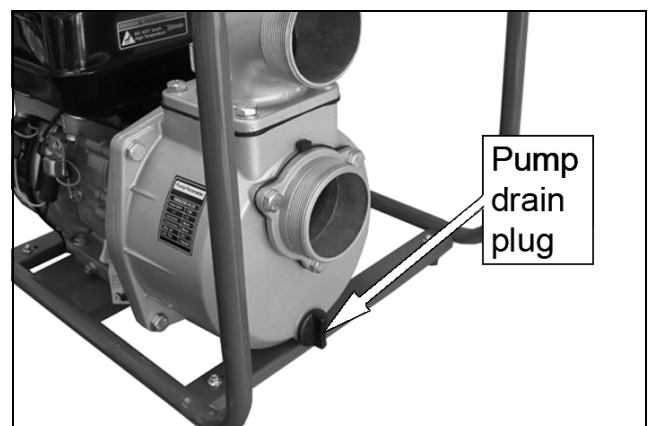

MAINTENANCE

CLEARING BLOCKAGES

1. Remove the hoses and adaptors from the pump.

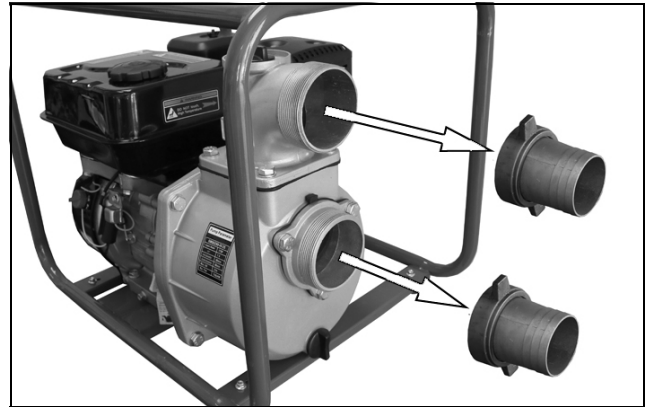

2. Remove the four bolts shown in the picture.
3. Remove the front cover.
4. Clear debris and clean the inner parts using clean water.
5. Replace the front cover and secure using the four bolts removed in step 2.

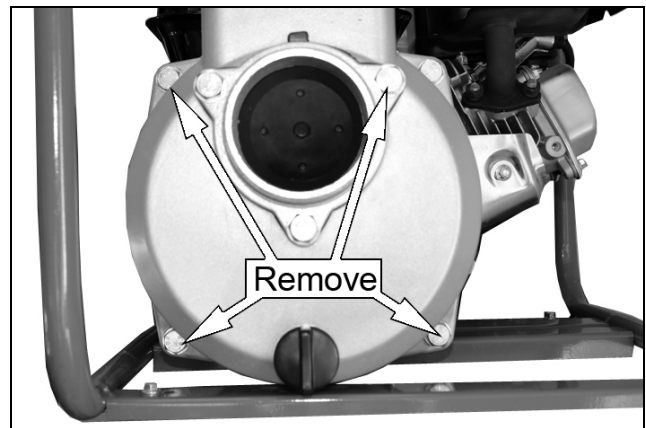

CHANGING THE ENGINE OIL



CAUTION: PROLONGED EXPOSURE TO USED ENGINE OIL IS DANGEROUS, ALWAYS WASH YOUR HANDS THOROUGHLY AFTER HANDLING USED ENGINE OIL.

Change the oil in the engine after the first 20 hours use and thereafter every 6 months or 100 running hours.

1. Unscrew and remove the oil filler cap/dipstick.

2. Put a oil collection tray below the drain plug.
3. Unscrew the drain plug and let the used engine oil drain from the crankcase into the oil collection tray.

NOTE: Drain the engine oil when the engine is warm, this will make sure that the oil flows out faster.

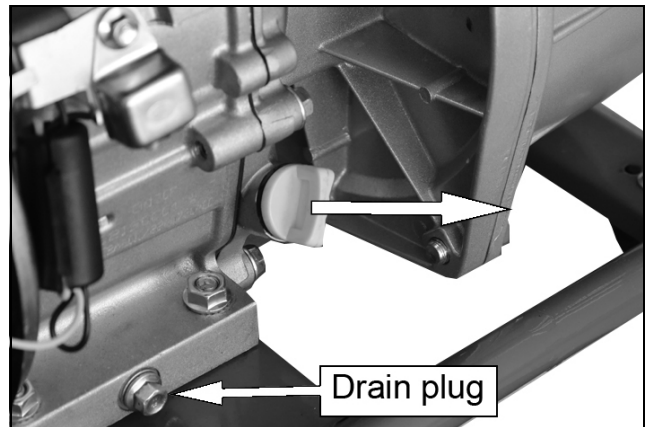

4. Replace the drain plug.
5. Fill the crankcase with engine oil.
 - Fill until the oil touches the threads in the oil fill tube.
 - Oil capacity (0.6 L).
 - We recommend that you use CLARKE SAE10W30 oil (Part No: 3050845) in this pump available from your CLARKE dealer.
6. Replace the oil filler cap/dipstick.

ENVIRONMENTAL PROTECTION

One of the most damaging sources of pollution is oil, **DO NOT** throw away or pour it down drains. Put it in a leak proof container and take it to your local waste disposal site.

CHANGING THE SPARK PLUG

Replace the spark plug after the first month or every 50 hours of use.

1. Remove the spark plug cap from the spark plug.



2. Use the spark plug spanner supplied to remove the spark plug.
3. Remove any carbon that has collected around the electrode.

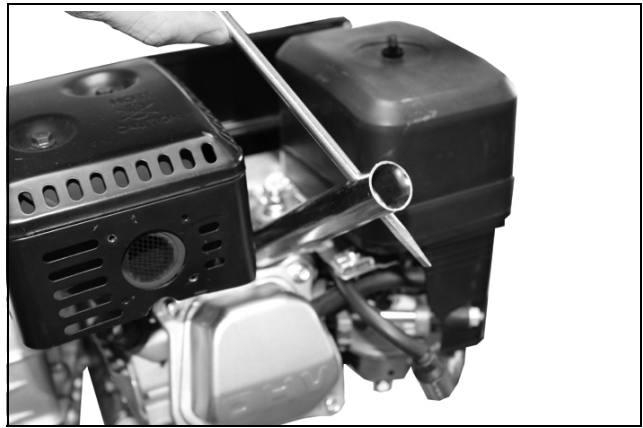

4. Check the spark plug gap (a), it should be between 0.7 and 0.8 mm, adjust if necessary.
5. Check the overall condition of the spark plug for erosion or pitting and replace if necessary.
6. Reinstall the spark plug and replace the spark plug cap.

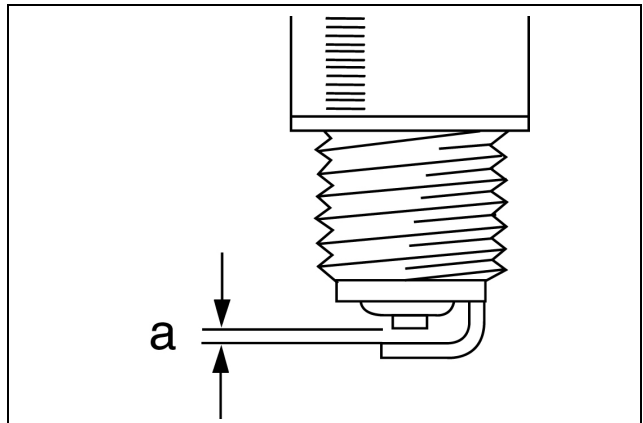

CHANGING THE AIR FILTER

Clean the air filter after 50 hours of operation (or more often in unusually dusty conditions) as follows.

1. Unscrew the wingnut and lift off the air filter cover.

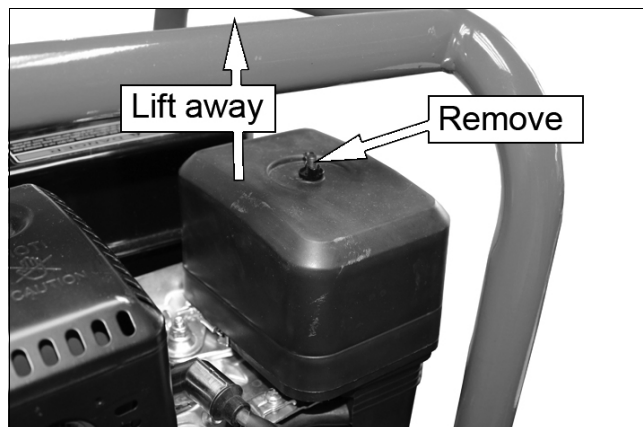

2. Remove the air filter element.
3. Clean the air filter or replace if necessary.
 - If the filter is dirty, wash the filter in a solution of warm water and mild detergent and rinse thoroughly. Leave the filter to dry completely,



4. Once it is dry, Dip in clean engine oil and squeeze out excess oil.
 - **DO NOT** operate the pump without the air cleaner installed as this will cause premature wear to the engine.

STORAGE

1. Always keep the pump in a dust and damp free environment away from children.

MAINTENANCE RECORD

OIL CHANGE:

SPARK PLUG CHANGE:

AIR FILTER CHANGE:

MISCELLANEOUS:

TROUBLESHOOTING

PROBLEM	CAUSE	SOLUTION
The engine does not start.	No fuel in tank.	Add fuel.
	Fuel valve is set to OFF	Set the fuel valve to ON.
	Engine switch is in the OFF position.	Set engine switch to the ON position.
	Lack of spark at the spark plug.	Make sure that the spark plug cover is fitted on to the plug. With the engine switch in the ON position, hold the spark plug electrode against the engine and pull the starter cord. If a spark is present but engine will not start, consult your CLARKE dealer.
The engine stops and will not restart.	No fuel in tank.	Add fuel to the tank.
The pump fails to prime.	Priming chamber not filled correctly.	Fill priming chamber leaving no air gap.
	Air leaking due to damaged hose, broken hose clamps, split/ill-fitting gasket.	Repair as necessary.
	Blocked inlet hose.	Clean strainer and make sure that it is not submerged in mud or sediment. Make sure that there are no kinks in the delivery hose.
	Engine speed too low.	Increase engine speed.
	Damaged impeller.	Disassemble the pump and replace the impeller.
	Air leaking through damaged seal.	Replace seal.

PROBLEM	CAUSE	SOLUTION
Low output from pump.	The engine speed is too low.	Increase the engine speed.
	Pickup or delivery hose obstructed.	Clear obstruction and make sure that there are no kinks in hose.
	Suction lift too high.	Set the pump nearer to the water level.
	Congested material inside pump.	Disassemble the pump and clean out.
	Damaged impeller.	Disassemble the pump and replace the impeller.

If you cannot correct the fault, speak to your local dealer or the CLARKE International service department.

ENVIRONMENTAL PROTECTION

At the end of its working life, DO NOT discard this pump or its components with general household waste. Packaging must be taken to a recycling centre and discarded appropriately.

One of the most dangerous sources of pollution is oil. DO NOT discard used oil with domestic refuse or flush down a sink or drain. Collect the oil in a leak-proof container and take it to your local waste disposal site.

SPECIFICATION

Item	Specification
Model No	PS50
Pump Dimensions (L X W X H)	505 x 405 x 440 mm
Pump Weight (Kgs)	22 kg
Water Classification	Semi-dirty water
Max Solids In Suspension	15 mm
Inlet/outlet Size	2" BSP
Maximum Flow	450l/min
Rated Head	28 m
Suction Head	7-8 m
Max Pressure	2.8 bar
Engine power	5.4HP
Fuel Tank Capacity (Petrol)	3.6 L
Fuel consumption	1.8L/hr
Lubrication Oil Capacity/grade	0.6 L (SAE 15W40)
Sound Pressure Level	87.95 dB LpA
Sound Power Level	101.1 dB LWA
Guaranteed Sound Power Level	104 dB LWA
Uncertainty Factor (K)	2.5 dB

COMPONENT PARTS

A full set of engine parts list and diagrams are available from the CLARKE International service department.

WATER PUMP ASSEMBLY

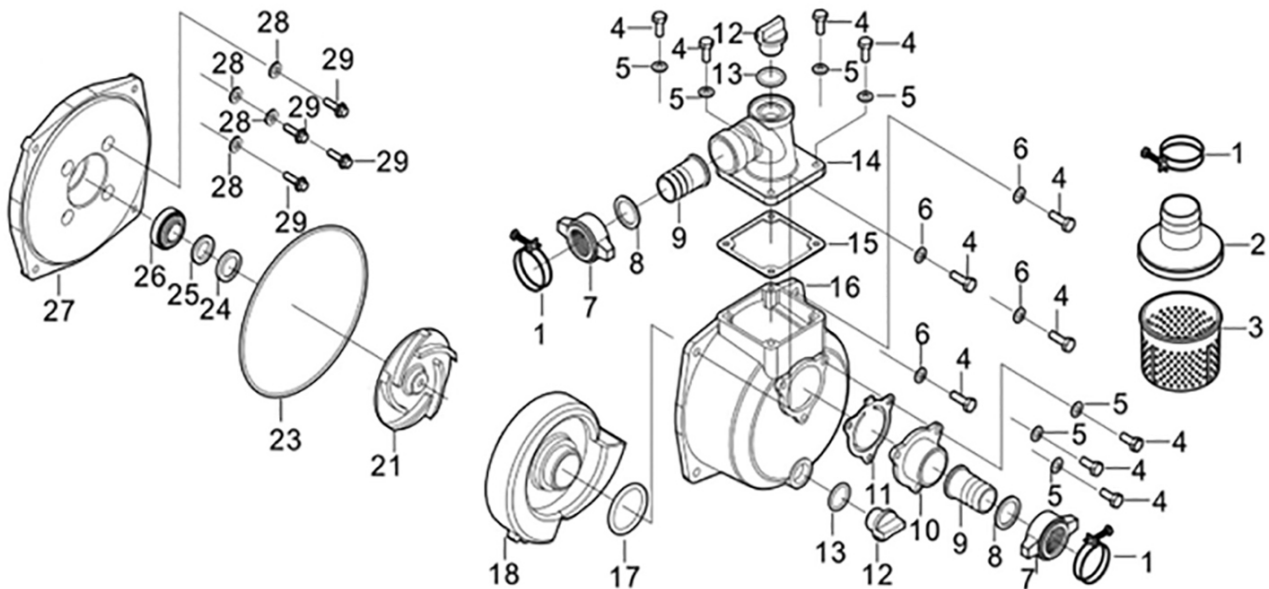

No	Description
1	Hose clip
2	Filter cover
3	Filter body
4	Bolt
5	Washer
6	Washer
7	Adaptor ring nut
8	Hose seal connector
9	2" pipe connector
10	Water inlet
11	Water inlet gasket
12	Plug
13	Washer for plug
14	Water outlet elbow
15	Outlet gasket

No	Description
16	Pump body
17	Case sealing
18	Casing
19	N/A
20	N/A
21	Impeller
22	n/a
23	Pump joint gasket
24	Seal
25	Porcelain seal
26	Seal assembly
27	Pump end plate
28	Washer
29	Bolt
30	Pump assembly complete



DECLARATION OF CONFORMITY

This is an important document and should be retained.

We hereby declare that this product(s) complies with the following legislation: The following standards have been applied to the product(s):

- Noise Emission in the Environment by Equipment for use Outdoors Regulations 2001* IEC 62321-4:2013/AMD1:2017, IEC 62321-5:2013, IEC 62321-6:2015, IEC 62321-7-1:2015,
- The Electromagnetic Compatibility Regulations 2016* IEC 62321-3-1:2013, IEC 62321-7-2:2017, EN ISO 3744:1995, IEC 62321-8:2017,
- The Supply of Machinery (Safety) Regulations 2008* EN 809:1998+A1:2009+AC:2010, EN 55012:2007+A1:2009

The Non-Road Mobile Machinery (Type-Approval and Emission of Gaseous and Particulate Pollutants) Regulations 2018

The Restriction of the Use of Certain Hazardous Substances in Electrical and Electronic Equipment Regulations 2012

The technical documentation required to demonstrate that the product(s) meet(s) the requirement(s) of the aforementioned legislation has been compiled and is available for inspection by the relevant enforcement authorities.

The UKCA mark was first applied in: 2024

Manufacturer:	Clarke International Ltd, Hemnall Street, Epping, Essex, CM16 4LG, United Kingdom	Notified Body:	N/A
Product Description:	Water Pump	Assessment Procedure:	Annex V of above noise legislation
Model Number(s):	PS50	Measured LWA:	101 dB
Serial/Batch Number:	Refer to product/packaging label	Guaranteed LWA:	104 dB
Document Holder:	Alan Pond	Signed:	 J.A Clarke Director
Date of Issue:	26/09/2024		

PS50 UKCA Clarke DOC 092624

Page 1 of 1

DECLARATIONS OF CONFORMITY - CE



DECLARATION OF CONFORMITY

This is an important document and should be retained.

We hereby declare that this product(s) complies with the following legislation: The following standards have been applied to the product(s):

2000/14/EC	Outdoor Noise Directive	IEC 62321-4:2013/AMD1:2017, IEC 62321-5:2013, IEC 62321-6:2015, IEC 62321-7-1:2015,
2014/30/EU	Electromagnetic Compatibility Directive	IEC 62321-3-1:2013, IEC 62321-7-2:2017, EN ISO 3744:1995, IEC 62321-8:2017,
2006/42/EC	Machinery Directive	EN 809:1998+A1:2009+AC:2010, EN 55012:2007+A1:2009
2016/1628	Particulate Emission and Type-Approval for Non-Road Mobile Machinery Regulation	
2011/65/EU	Restriction of Hazardous Substances (RoHS) Directive	

The technical documentation required to demonstrate that the product(s) meet(s) the requirement(s) of the aforementioned legislation has been compiled and is available for inspection by the relevant enforcement authorities.

The CE mark was first applied in: 2024

Manufacturer:	Clarke International Ltd, Fitzwilliam Hall, Fitzwilliam Place, Dublin 2, Republic of Ireland	Notified Body:	N/A
Product Description:	Water Pump	Assessment Procedure:	Annex V of above noise legislation
Model Number(s):	PS50	Measured LWA:	101 dB
Serial/Batch Number:	Refer to product/packaging label	Guaranteed LWA:	104 dB
Document Holder:	Alan Pond	Signed:	 J.A Clarke Director
Date of Issue:	26/09/2024		

A SELECTION FROM THE VAST RANGE OF

Clarke®

QUALITY PRODUCTS



AIR COMPRESSORS
From DIY to industrial, Plus air tools, spray guns and accessories.

GENERATORS
Prime duty or emergency standby for business, home and leisure.

POWER WASHERS
Hot and cold, electric and engine driven - we have what you need

WELDERS
Mig, Arc, Tig and Spot. From DIY to auto/industrial.

METALWORKING
Drills, grinders and saws for DIY and professional use.

WOODWORKING
Saws, sanders, lathes, mortisers and dust extraction.

HYDRAULICS
Cranes, body repair kits, transmission jacks for all types of workshop use.

WATER PUMPS
Submersible, electric and engine driven for DIY, agriculture and industry.

POWERTOOLS
Angle grinders, cordless drill sets, saws and sanders.

STARTERS/CHARGERS
All sizes for car and commercial use.



PARTS & SERVICE: 0208 988 7400

Parts Enquiries
Parts@clarkeinternational.com

Servicing & Technical Enquiries
Service@clarkeinternational.com

SALES: UK 01992 565333 or Export 00 44 (0)1992 565335

Clarke® INTERNATIONAL Hemnall Street, Epping, Essex CM16 4LG
www.clarkeinternational.com